

Ancona® Electric

Made to order



3 Column 600mm x 833mm in White RAL 9016

Ancona® Electric shown on page 31



High quality Italian design & manufacture
 Steel Multi Column 3 column with wall brackets only
 Eco Design
 10 year guarantee on the radiator
 2 year guarantee on the element

White RAL 9016

Made to Order: Up to 5 weeks



The Ancona electric ranges combine the classic Ancona design with the flexibility of a fully controllable electric element. Offering 8 function modes, the Ancona Electric can be set to operate when you wish, on a daily basis or you can select one of the three pre-set programmes. The Open Window function detects an open external door or window and will turn the radiator off if it is allowing heat to escape so saving energy and money.

Ancona® Electric

Height (mm)	Width B (mm)	Sections	Model	Watts Δt 50°C
600	428	8	ANCO3C6036EW	400
	608	12	ANCO3C6054EW	600
	698	14	ANCO3C6063EW	800
	833	17	ANCO3C6076EW	1000
	968	20	ANCO3C6090EW	1200
	1103	23	ANCO3C6010EW	1500
	1373	29	ANCO3C6013EW	2000

- IP 44
- 8 operating modes: weekly program, 3 integrated pre-set timed programs, pilot-wire facility, comfort, night and antifreeze.
- Window open function
- Comfort, Night and Antifreeze
- 2 Year Guarantee on the element

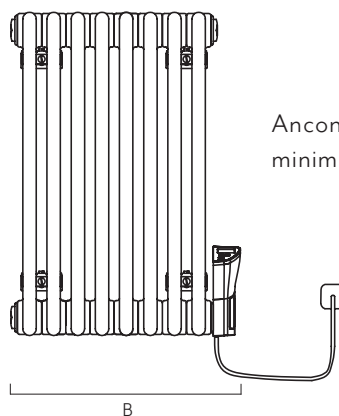
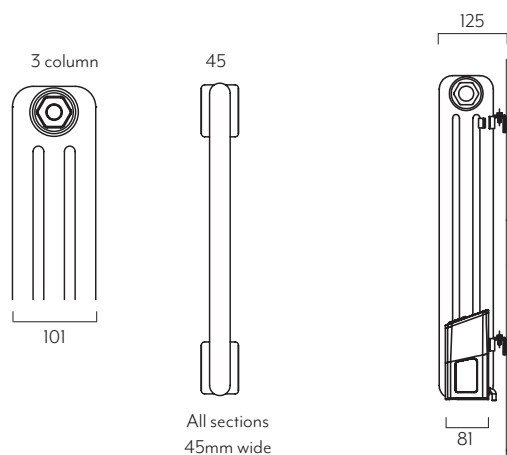

Ancona Electric radiators must be hung a minimum of 150mm off the floor

Technical Specifications

Materials	Steel.
Packaging	Polythene wrap and boxed
Voltage-feed	230V 50Hz, 1ph
Insulation Class	II
Protection degree	IP44
Length electrical cable	1200mm

Electronic ambient thermostat with "pilot wire" control

The thermostat can work exclusively when paired with a specially prepared electric heating element, equipped with safety devices to limit excess temperature and make the system safe in the event of abnormal factors (see Warnings).

Maintenance - Recommendations for use

- This radiator should be cleaned regularly, particularly when in use (at least once a month). Switch off at the socket before cleaning the radiator. Clean it using a non-abrasive product and a soft cloth.
- If you wish to open the window, it is advisable to switch the radiator to standby to save wasting energy.
- If you encounter any problems or the radiator needs to be repaired, do not do this yourself; Please contact The Radiator Company.

Recycling



In accordance with article 14 of the Directive 2012/19/UE of 07/07/2012 on waste electrical and electronic equipment.

The symbol shown left, also present on the equipment, indicates that it has been placed on the market and that, when the user decides to get rid of it, it must be disposed of in separate waste collection (including all the components, sub-assemblies and consumer materials which are an integral part of the product).

For information on the systems for collecting these appliances, please contact The Radiator Company. Waste produced in the home (or of similar origin) may be consigned to systems for the separate collection of urban waste.

When buying a new appliance of an equivalent type, it is possible to hand over the old equipment to the seller. The seller will then contact the subject in charge of the collection of the equipment.

The appropriate separate collection of the scrapped equipment and the subsequent operations of processing, recovery and environment-compatible disposal, allows the avoidance of potential negative effects on the environment and on human health, while favouring the recycling and recovery of the component materials.

Guarantees & Liabilities

The Ancona Electric Radiator is guaranteed for 10 years, the electric parts for 2 years. The guarantees in all cases are subject to the products being installed in accordance with British and or European standards as well as these fitting instructions. The guarantees in all cases are restricted to the free of charge replacement or repair of the failed product only. Our liability will under no circumstances extend beyond the repair or replacement of the product supplied by us. Claims for either labour in replacement or damage to property are not admissible. Any goods that are returned, in the event of a problem, will belong to The Radiator Company.

Fittings Instructions

The Radiator Company
Units 13 - 14 Charlwoods Road
East Grinstead
West Sussex
RH19 2HU



The Ancona® Electric provides the option to place your radiator in spaces where it is not possible or convenient to connect to the normal heating system.

Please read these instructions and terms and conditions carefully prior to installation. Failure to do so may invalidate the warranty.

Terms & Conditions

All products must be inspected once removed from the packaging and The Radiator Company notified within 28 days of delivery of any scratches, blemishes or other damage. The Radiator Company will then replace the radiator.

Imperfect radiators should therefore not be fitted and The Radiator Company will not accept responsibility for replacement of scratched or damaged radiators once they have been fitted. This includes any consequential loss or cost of fitting.

If The Radiator Company are not notified within 28 days of the date on the signed delivery note then it will be deemed that The Radiator Company have fully complied with its obligations and claims will not be considered.

Failure to comply with any of the above may invalidate any claims.

We recommend that after you check the product on delivery that it is stored in its packaging to prevent damage prior to installation. The Radiator Company cannot accept responsibility for items damaged after delivery.

Diagrams of Ancona®

The correct number of Universal Wall Brackets (which act as wall ties too) are supplied with each order.

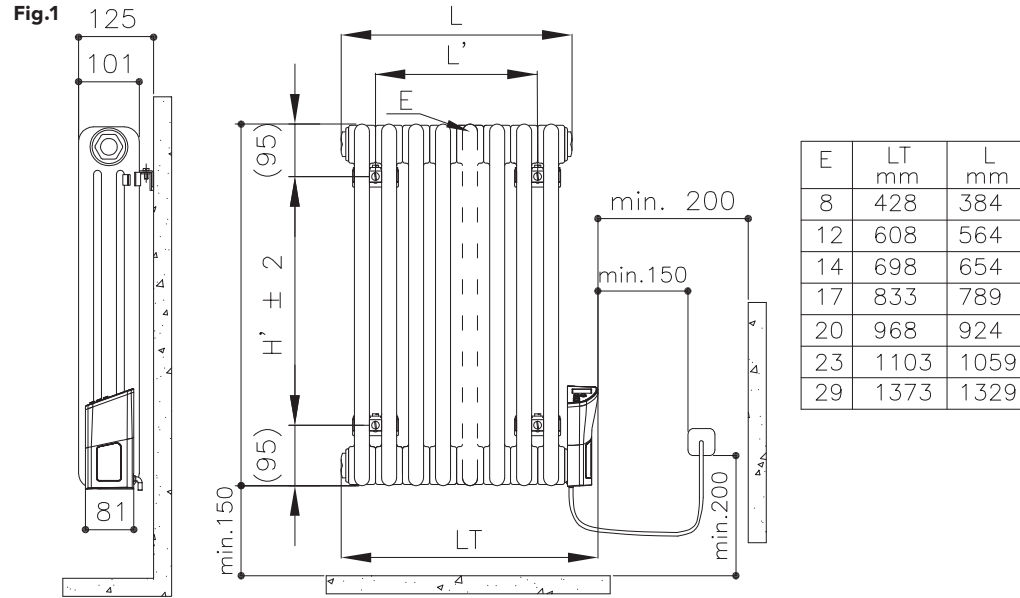

Universal Wall Brackets should be logically positioned to prevent Ancona Electric radiators from falling away from the wall. Please refer to 3. Mark Bracket Positions & Hang Radiator (right)

Please note Ancona Electric radiators must be at least 150mm off floor level and the plug position 200mm from floor level.

WARNING

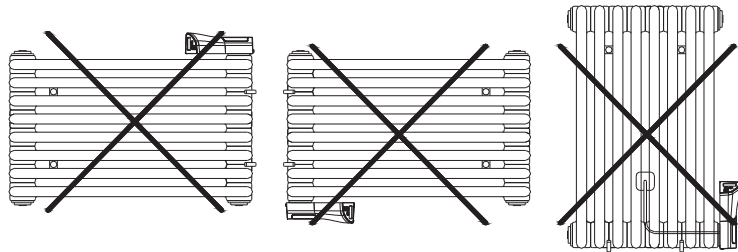

1 Unpack & Inspect / Contents

All of our products are well packaged & should reach you in perfect condition. The Radiator Company must be notified of any shortages or damage within 28 days of delivery. For further information please see terms and conditions on back page.

You should have:

- 1 Radiator
- 4 Universal Wall Brackets

You will need:

- Tape measure
- Electric drill and bits
- Spirit level
- Screwdrivers
- Allen Key

2 Mark Bracket Positions & Hang Radiator

The Universal wall bracket is a clamp style with a separate mounting plate that is fixed to the wall. When securing the brackets to the radiator wrap masking tape around your screwdriver to reduce the risk of damaging the paint finish.

Please refer to **fig.1** for bracket positions, vertical bracket positions can be found by measuring the width of the radiator (not including the element) less 44mm.

Mount the brackets 95mm down from the top of the radiator and 95mm up from the bottom.

With all bracket positions fixed, the radiator is placed in its final position.

3 Electrical Connection

This radiator is designed for connection to a ~230 V power supply with a fixed socket. It comes with a connecting cable (A O5 VVF)

The cable must be connected to a junction box behind the radiator in compliance with the applicable standards.

It is necessary to install an omnipolar cut-out, with a contact distance of at least 3mm.

If the power cable gets damaged or needs to be changed, as a safety precaution it must be replaced by the manufacturer, an authorised after-sales service or a qualified Part P competent person.

4 Operation & Setting

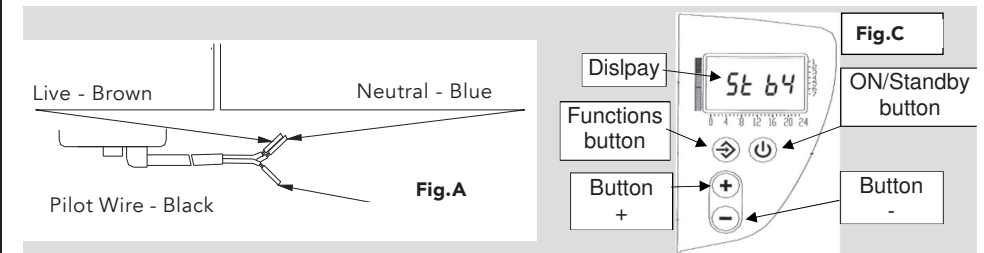

If the pilot-wire (Fig.A) is not connected, safety requires that it be insulated & in no way connected to earth

HEATING ELEMENT TECHNICAL CHARACTERISTICS

The thermostat can work exclusively when paired with a specially prepared electric heating element, equipped with safety devices to limit excess temperature and make the system safe in the event of abnormal factors (see Warnings).

INSTALLATION

Children younger than 3 years old should be kept at a distance, if they are not continuously supervised. Always fix the radiator to the wall as per the assembly instructions above.

The installation must be carried out by a specialized firm in compliance with the standards in force.

When installing the radiator, the BS EN 60364-7-701 according to the edition in force must be complied. For the supply of the radiator, an omnipolar switch with at least 3 mm of distance between contacts, must be employed.

When installing in bathrooms or in shower-rooms, the appliance should be installed in such a way to avoid the switch and other controls to be reached by people using the bathroom or the shower. (see **Fig. B** right)

The radiator must not be installed immediately beneath a fixed current outlet.

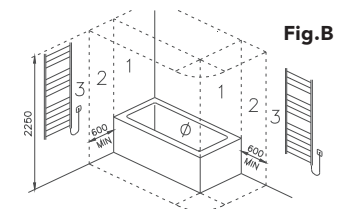

4 Operation & Setting

DIRECTIONS FOR USE

The radiator must be used only for the purpose described in the manual. In particular, children must not play with the appliance.

Do not apply put accessories other than those recommended by The Radiator Company on the radiator.

Connect the radiator to the mains power supply after it has been fixed to the wall.

Children under 3 must be kept at a distance unless under continuous surveillance.

Children between 3 and 14 years of age and persons with reduced physical, sensory or learning difficulties, or who lack experience or the necessary knowledge can use the radiator on condition that it has been positioned or installed in the normal position contemplated and they have been instructed and trained in its safe use and are aware of the potential risks.

Children under the age of 14 must not connect the power plug, nor adjust or clean the appliance.

Children and persons with reduced physical, sensory or learning difficulties, or who lack experience or the necessary knowledge must not perform cleaning or routine maintenance of the radiator.

It is absolutely prohibited:

- To power the heating element control before having checked the correct installation of the thermostat on the radiator.
- To cut the power supply cable to disconnect the appliance
- To damage the power supply cable. If the power cable is damaged the complete electric heating element must be repaired or replaced by the manufacturer or by their technical assistance service, or by a qualified person authorised by the manufacturer, so as to prevent any risk.

WARNING

DURING OPERATION, THE RADIATOR CAN GET VERY HOT, AND CAUSE BURNS UNLESS SPECIAL CARE IS TAKEN. Particular attention should be paid to the presence of children and vulnerable people

Do not use corrosive or abrasive products or solvents to clean the radiator or the plastic parts that contain the electrical parts.

(Fig. C)

The electronic control consists of a thermostat that allows you to choose the ambient temperature from 7°C to 35°C.

The electronic thermostat has 4 buttons and 1 display (**Figure 1 below**). The electronic thermostat is started by pressing the [ON/Standby] button: when the electronic thermostat is in standby, the flashing letters "St by" appear on the display; when it is in the chrono modes, the program appears with the indication of the time or the number of the selected integrated program (P1, P2, P3), or the setting of the mode temperature.

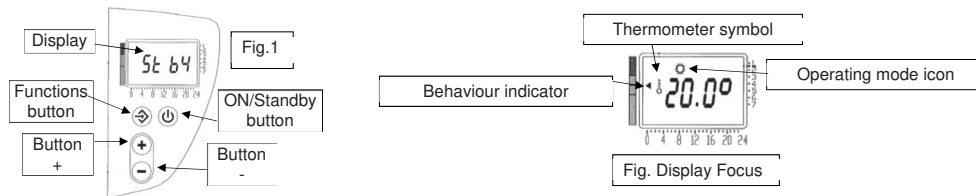

STAND-BY OPERATION

When changing from STAND-BY to one of the operating modes, the electronic thermostat emits a sound lasting 1 second. Vice-versa, when changing from one of the operating modes to STAND-BY, the electronic thermostat emits two short sounds with a pause of half a second between them.

When it is powered, the electronic thermostat emits a warning sound to indicate its status according to the logic described above.

Next to the display is a coloured bar: an arrow on the display indicates one of the three colours depending on the current temperature setting, as in the table below. This indicator provides a visual indication that setting high temperatures results in a higher energy consumption.

Colour	Temperature setting
Red	>24 °C
Yellow	>19 °C and ≤24 °C
Green	≤19 °C

Table 1: Indication of consumption

4 Operation & Setting

DESCRIPTION OF USE

The electronic thermostat has 8 operating modes: 1 pre-set free chrono program, 3 integrated chrono programs, pilot-wire, comfort, night and antifreeze. To change from one mode to another, press the FUNCTIONS button.

Table 2: Operating modes

Operating mode	Icon	Operating mode description
CHRONO		Follows the weekly programming on two temperature levels (high and low) defined by the user hour by hour. All the PILOT-WIRE controls are disabled except STOP.
P1 FIXED PROGRAM		P1 fixed weekly program (working week program) on two temperature levels (high and low) pre-defined time hour by hour. All the PILOT-WIRE controls are disabled except STOP.
P2 FIXED PROGRAM		P2 fixed weekly program (working week program) on two temperature levels (high and low) pre-defined time hour by hour. All the PILOT-WIRE controls are disabled except STOP.
P3 FIXED PROGRAM		P3 fixed weekly program (working week program) on two temperature levels (high and low) pre-defined time hour by hour. All the PILOT-WIRE controls are disabled except STOP.
PILOT-WIRE		The locally set high temperature is modified according to the controls received from the Pilot-Wire unit, except in the case where the Pilot-Wire is not connected, or with class 1 regulators (products with an earth connection). The ELECTRONIC THERMOSTAT recognises 6 controls: comfort, reduction (high temperature -3.5°C), stop, antifreeze (7°C), eco1 (high temperature -1°C) and eco2 (high temperature -2°C)
COMFORT		Regulation without time limits on the high temperature level. All the PILOT-WIRE controls are disabled except STOP.
NIGHT		Regulation without time limits on the low temperature level. All the PILOT-WIRE controls are disabled except STOP.
ANTIFREEZE		Regulation without time limits on 7°C. All the PILOT-WIRE controls are disabled except STOP.

Two different temperature levels can be set, high and low. High temperature is used in the chrono modes, P1, P2, P3, Pilot-Wire and comfort. Low temperature is used in the chrono modes, P1, P2, P3 and night. High temperature can be modified in comfort mode while low temperature can be modified in night mode using the [+] and [-] keys. The flashing thermometer symbol indicates that modification is in progress. During modification, the high temperature can be decreased to the current low temperature value and, vice-versa, the low temperature can be increased to the current high temperature value.

IMPORTANT: changes in the ambient temperature are normal when using electronic thermostats when there are variations in the power requested or when the environmental conditions change outside the room that is to be heated. The set value is correct only for radiators installed in standard environments. It is normal for the regulator setting to be different to obtain the same temperature in different environments (influence of the surrounding environment).

In chrono mode the temperature levels are used as illustrated in figure 3 below.

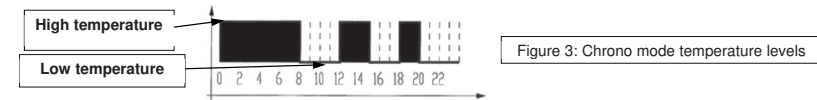

KEY LOCK

This function allows you to block the use of the keys. It may be useful to activate this setting to avoid accidental changing of settings by unauthorised persons or children. To activate it, hold down the [+] and [-] keys together for at least 3 seconds.

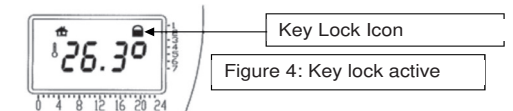

A padlock icon appears when the keys are locked, **figure 4**. With the key lock active, it is still possible to put the thermostat in standby or in operation by pressing the [ON/Standby] button, but it is not possible to change the temperature setting and the operating mode.

To deactivate the function, hold down the [+] and [-] keys together again for at least 3 seconds. The padlock icon disappears and the buttons resume the normal functions.

For safety reasons, always prevent children playing with this product.

4 Operation & Setting

TIME SETTING AND FREE WEEKLY PROGRAMMING

Hold down the [ON/standby] and [Functions] buttons together for at least 3 seconds. The hour numbers will start to flash. Use [+] and [-] to set the current hour and press the [Functions] button to confirm. Set the current minutes and day in the same way. The latter is indicated by a corresponding point on the vertical numbered scale, **figure 5 below**.

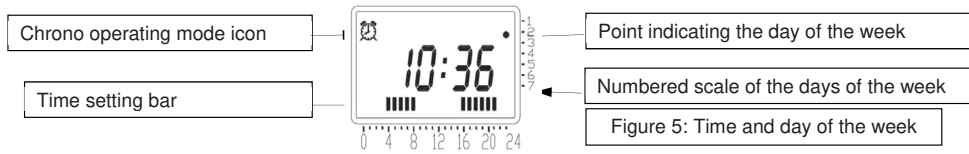

After the time, proceed to the weekly programming. Set the sequence for each hour and for each day of the week. The selection is made using the [+] and [-] keys; at that time [+] regulates the high temperature and [-] the low temperature. On the time setting bar, a dash corresponds to the high temperature and the empty space corresponds to the low temperature. Press the [Functions] button to save the day and start the next day with the same procedure. For example, to have a high temperature from 6 to 10 a.m. and from 7 to 11 p.m. (and a low temperature in the remaining intervals), see **figure 6**.

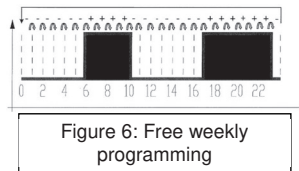

If the [ON/Standby] button is pressed when setting the time and the weekly programming, the electronic thermostat goes into standby status and the new time/date setting is saved, while the new weekly programming is not saved. Pressing the [ON/Standby] button again brings the thermostat into the present status before starting the procedure for setting the time.

If there is an interruption in the 230V ac power supply, the weekly programming made remains in the memory, along with the current mode (including keyboard lock) and the high and low temperature settings, while the time must be reset. When the 230V ac power returns, if one of the chrono modes is selected (free weekly programming P1, P2 or P3) the "Chrono" symbol flashes and the writing on the display (the current time or P1, P2 and P3 depending on the mode): in this case, follow the procedure illustrated at the start of the paragraph to reset the current time. Until the operation is performed, the thermostat provisionally counts the time that passes from the moment the 230V ac power returns (and this "provisional" time is used if one of the chrono modes is selected).

INTEGRATED WEEKLY PROGRAMMING

As well as the classic weekly programming defined by the user, the electronic thermostat has 3 integrated programs named respectively P1, P2 and P3. To change from one to another, press the [Functions] button to select the desired mode as in **figure 7**.

Modes P1, P2 and P3 are fixed and are set as follows:

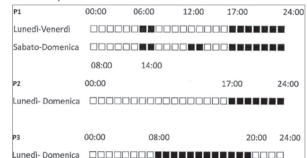

where:
 ■ = high temperature ("Comfort");
 □ = low temperature ("ECO").

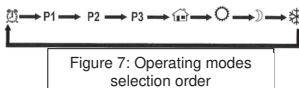

The programs P1, P2 and P3 are completely independent of one another and can only be used one at a time. If one of these is selected (for example P3), the display appears as in **figure 8**. The flashing dash (in grey in **figure 8**) indicated the time interval currently active.



Figure 8: Program P3 active.

If the user wants to use a weekly program other than P1, P2 or P3, he can make one with his own settings using the standard chrono program illustrated in the previous paragraph.

4 Operation & Setting

PILOT-WIRE MODE

The locally set high temperature in comfort mode is modified according to the controls received from the Pilot-Wire unit, except in the case where the Pilot-Wire is not connected, or with class 1 regulators (products with an earth connection).

NOTE: if the Pilot Wire is not installed in the system, the predefined operating mode is "Comfort". In this case, do not connect the Pilot Wire cable of the thermostat to the earth cable and insulated it.

The thermostat recognises 6 controls: comfort, reduction (high temperature -3.5°C), stop, antifreeze (7°C), eco1 (high temperature -1°C) and eco2 (high temperature -2°C). The display appears as in **figure 9**. The Stop command is enabled in all modes except standby.

If the Stop command has been received outside Pilot-Wire mode, the icon flashes.

With the Stop command present it is still possible to put the electronic thermostat in standby status by pressing the [ON/Standby] button.

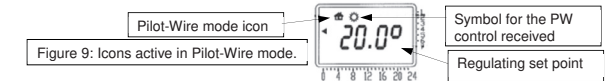

Figure 9: Icons active in Pilot-Wire mode.

Table 3: Pilot-Wire controls

Pilot-Wire control	Icon	Set point/message displayed
Comfort		High temperature
Reduction		High temperature - 3.5°C
ECO1		High temperature - 1°C
ECO2		High temperature - 2°C
Antifreeze		7°C
Stop		Stop

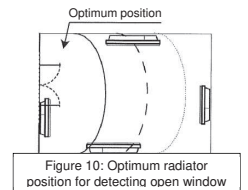

Figure 10: Optimum radiator position for detecting open window

WINDOW DETECTION FUNCTION

This function allows you to avoid wasting energy if the room in which the radiator is located is being aired by opening a window or a door that leads onto a colder environment. As detection is indirect, the intervention of the function is linked to different variables, including the environment temperature and the outdoor temperature, the position of the radiator, the time passed since the window was opened/closed, the type of construction of the room and, last but not least, the radiator status. The optimum position of the radiator in the room is near the window, as shown in **figure 10**.

If the function is active, the system detects when the window is open or closed. The function can be selected and activated only in Comfort mode

("sun" icon lit) or Pilot-Wire mode ("house" icon lit), with the comfort signal present.

To activate the function hold down the [Functions] and [-] keys together for a few seconds until the message "F on" appears on the display, after which the system returns to the previous screen, **figure 11**.

When the system detects that the window is open, the "antifreeze" icon also appears on the display and flashes continuously (in grey in **figure 12**), while at the internal regulation level the set-point is set at 7°C. This status remains until closing of the window is detected, or until 2 hours have passed, which is the maximum period after which the radiator will start heating again in any case.

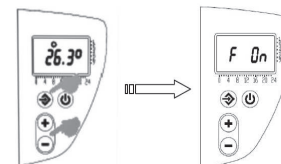

Figure 11: Activation of the open window detection function

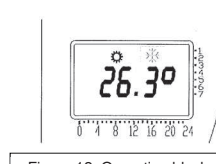

Figure 12: Operation blocked after detecting open window

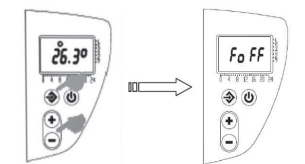

Figure 13: Deactivation of the open window detection function

To exclude the function hold down the [Functions] and [-] keys together for a few seconds until the message "F off" appears on the display, after which the system returns to the previous screen, **figure 13**.

NOTE 1: If the electronic thermostat seems to be working correctly and the radiator is not heating at all, this situation indicates a probable intervention of the protection devices built into the heating element. If the message "Err1" appears on the display, it means that the ambient temperature sensor is damaged or that the temperature is outside the allowed operating limits.

NOTE 2: in the case of faults or malfunctions, contact the assistance service; no spare parts are provided.