

All dimensions shown are in millimetres

- Max working pressure: **5 BAR**
- Max working temperature: **120° C**
- All steel construction: **dia 31.8mm round tubes**
- Connections: **½ inch BSP tappings**
- Electrical connection: **1.2m long flying lead (3 core)**
- Immersion heater rating: **IPX4 or better**

Heat output determined in accordance with EN 442

Model	Immersion Output Watts	Output ΔT=30K Watts	Output ΔT=50K Watts	n	Water Content litres	Weight kg	Height ± 2mm	Length ± 2mm	Tapping Centres ± 2mm	Fixing Centres ± 5mm
BALMM/F	400	355	683	1.31	10	24	850	735	n/a	n/a

Tools & Material Required

Suitable valves
 PTFE tape
 Silicone thread sealant
 Allen key - 13mm & 12mm (when installing Bisque valves)
 Spanner - 13mm & 14mm
 Screwdriver - flathead
 Electric drill
 Masonry drill bit

Key	Component	Qty
A	Air Vent	1
B	Screw	12

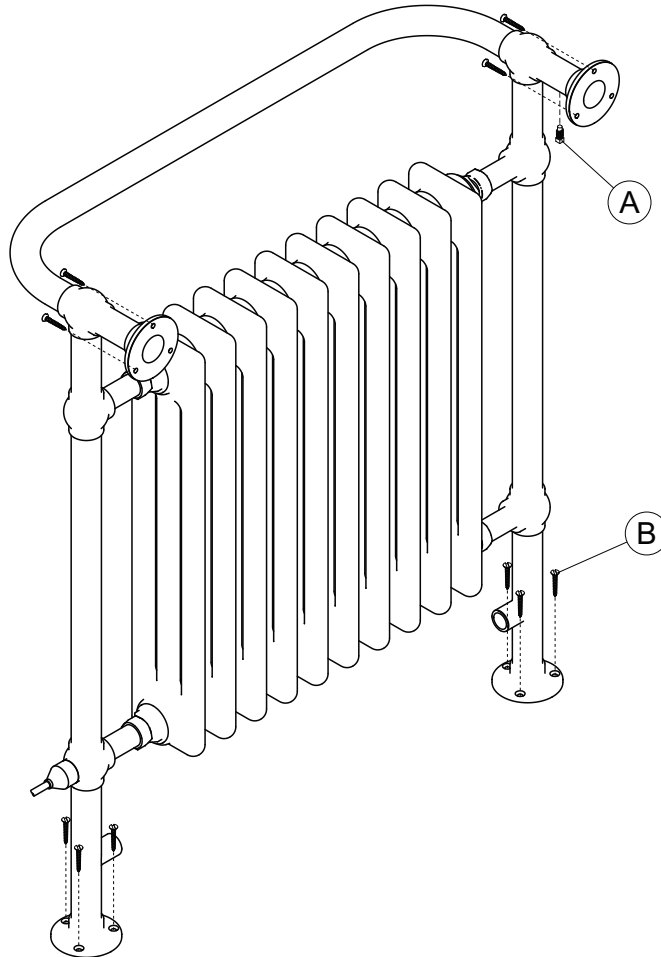

Assembly Instructions

Sufficient PTFE tape must be applied to valve-tail threads prior to their installation.
 Silicone thread sealant should be applied to all threaded components manufactured with 'O-rings'.

Fit valve tails, using correct size Allen key.

Fit air vent (A).

Accurately mark out bracket holes on floor & wall.

Drill twelve fixing holes. Screws (B) are supplied but ensure that appropriate fixings are used for the type of wall the radiator is being mounted on.

Screw radiator to floor & wall.

Plumb radiator to heating circuit. To enable more efficient bleeding of the radiator, it is recommended that the flow enters the radiator in the right-hand header.

This radiator should be installed onto a central heating system that has been cleaned/flushed and contains water treatment and inhibitors in accordance with BS7593.

Electric radiators should be fitted only by a qualified electrician and must be earthed and connected to a cable outlet in the bathroom in accordance with I.E.E. wiring regulations. The electrical connection should be made to a '5 amp fused fixed spur' located outside the bathroom.

Note: for maintenance purposes, cable outlets must remain accessible and cables must not be buried directly into walls.