

ALL MEASUREMENTS ARE IN MILLIMETRES MANUFACTURED FROM MILD STEEL

DOUBLE

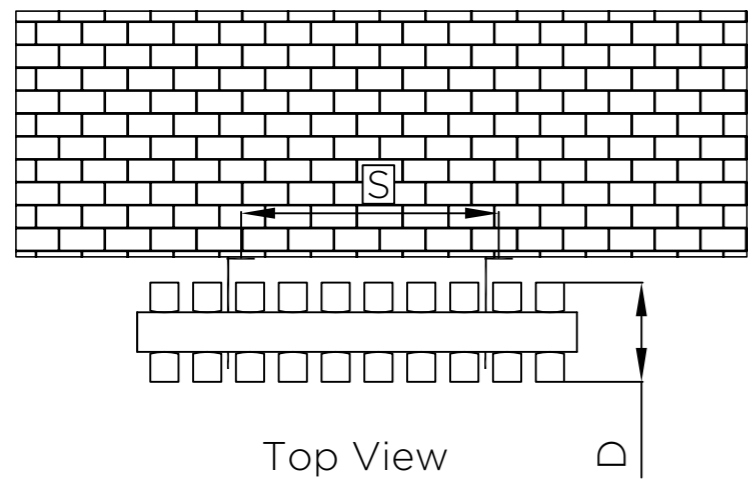
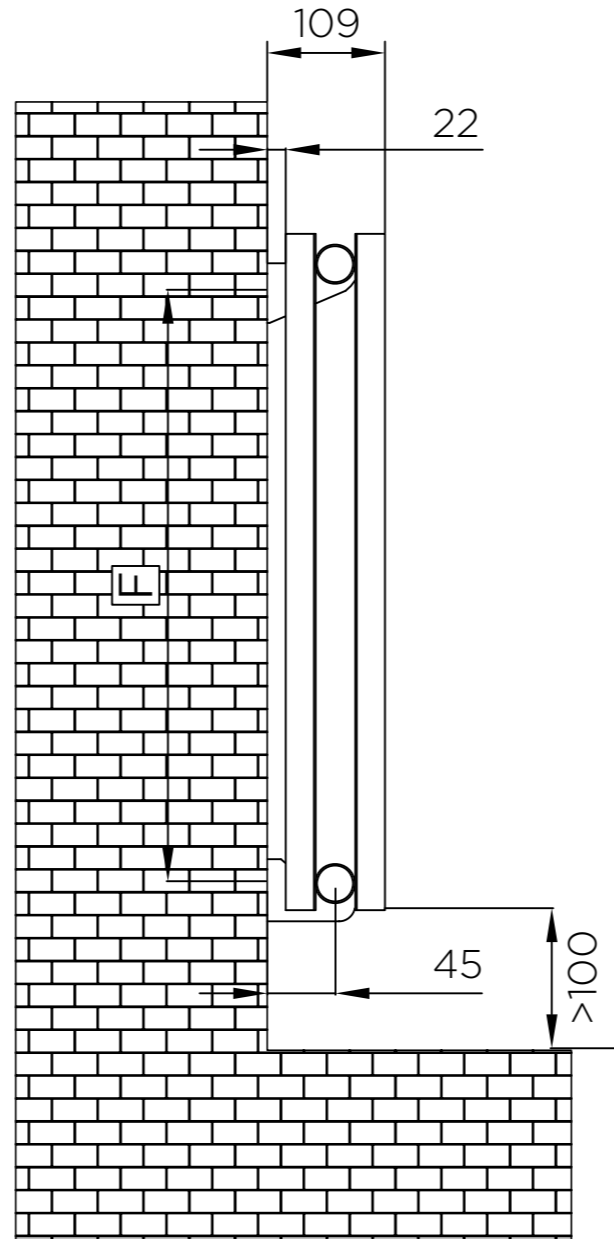
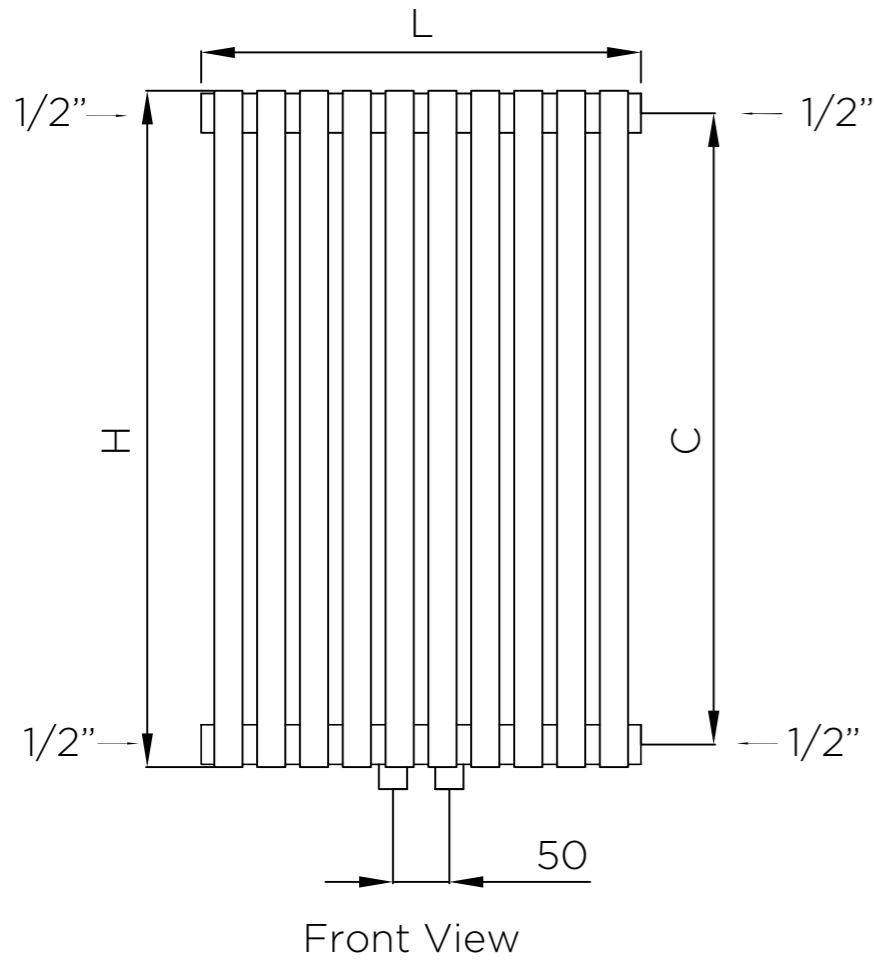

All Dimensions are in mm
 Max.Working Pressure = 6 Bar
 Max.Working Temperature=95° C
 Inlet / Outlet : 1/2" BSP
 Fuel: H

Installation Accessories:

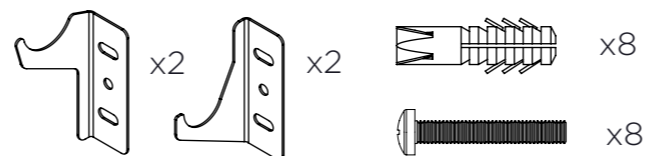

PRODUCT CODE	HEIGHT (H)	LENGTH (L)	DEPTH (D)	COLLECTOR TUBE CENTRES (C)	BRACKET CENTRES	
	mm				F	S
KD416	420	611	87	376	351	456
KD422	420	839	87	376	351	684
KD428	420	1067	87	376	351	912
KD432	420	1219	87	376	351	1064
KD436	420	1371	87	376	351	1216
KD614	600	535	87	556	531	380
KD616	600	611	87	556	531	456
KD622	600	839	87	556	531	684
KD628	600	1067	87	556	531	912
KD632	600	1219	87	556	531	1064
KD636	600	1371	87	556	531	1216
KD642	600	1599	87	556	531	1444